

# Thermocouple type J G1/2 " with silicone cable

**Order nr.: 803160 1111**

Screw-in thermocouples with silicone cable measure the temperature in pipes or vessels and can be used from -50 °C to +180 °C. Silicone seals well and remains flexible even at temperatures below freezing. To configure your screw-in thermocouple for your measurement task, simply select the required configuration features and send us the order code.

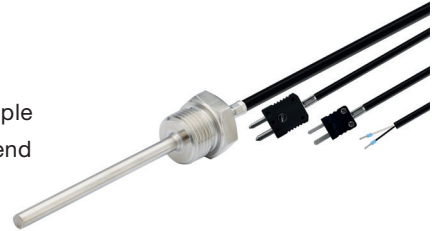

General Information	
Measuring range	-40 °C to +180 °C
Perm. °C range cable	-50 °C to +180 °C
Accuracy	-40 °C to +375 °C: ±1,5 °C according to DIN IEC 60584 Class 1
Response time	t63 / t99: information is available on request
Pull-out force	≥ 30 N
Supply and output	
Measuring element	Thermocouple Type J
Measuring point	Measuring point isolated
Measurement signal	Thermovoltage
Ambient conditions	
Protection class	IP65 according DIN 60529 (depending on cable)
Humidity and moisture condensation resistance	according to application-specific qualification
Certificates and Standards	
Standards	DIN EN 61326-1:2013   DIN EN IEC 63000:2019-05
Directive	RoHS 2011/65/EU   2014/30/EU
Certificates	Certificate of suitability (on request)



**Customizable options**

- C - Mounting length
- E - Material connection cable
- F - Length connection cable
- G - Connector
- H - Bend protection

Screw-in thread					
Bild	Screw-in thread		C - Mounting length		Zeichnung
	Material	Stainless steel 1.4301   SUS 304	<b>Code</b>	<b>Length (mm)</b>	
	Length (mm)	14	C0050	50 <sup>1)</sup>	
	Process connection	G1/2 "	C0100	100 <sup>1)</sup>	
	Wrench size	24	C0150	150 <sup>1)</sup>	
	<b>Protection sleeve</b>		C0200	200 <sup>1)</sup>	
	Material	Stainless steel 1.4571   316TI	C0250	250 <sup>1)</sup>	
	Mounting length (mm)	please choose	C0300	300 <sup>1)</sup>	
	Ø (mm)	6 <sup>2)</sup>	C0400	400 <sup>1)</sup>	
			C0500	500 <sup>1)</sup>	

Other mounting lengths on request | <sup>1)</sup>Tolerance ± 1% | <sup>2)</sup> Tolerance ± 0,1 mm

E - Cable material and configuration connection cable												
Code	Type	Color	IP	From (°C) <sup>1)</sup>	To (°C) <sup>1)</sup>	Outside material	Material strand	Ø (mm) <sup>2)</sup>	Q (mm <sup>2</sup> )	Color strand	Ω / m <sup>4)</sup>	
E8210	Thermocouple cable	Type J <sup>3)</sup>	IP67	-50	+180	Silicone	FEP	3,6	0,22	bk, wt	2,5	



Insulation resistance: ≥ 100 MOhm at min. 100 VDC | <sup>1)</sup>Perm. range °C | <sup>2)</sup>Tolerance ± 0,2 mm | <sup>3)</sup>Color according to IEC 584 | <sup>4)</sup>per thermocouple

RL / KS / 28.10.2021





F - Length								
Code	F010	F020	F030	F040	F050	F100	F150	F200
m	1	2	3	4	5	10	15	20

Other lengths on request

G - Connector					
Picture	Code	Feature	Picture	Code	Feature
	G01	Insulated end ferrules (50 mm)			
	G11	Mini-TC connector Type J bk		G31	TC connector Type J bk

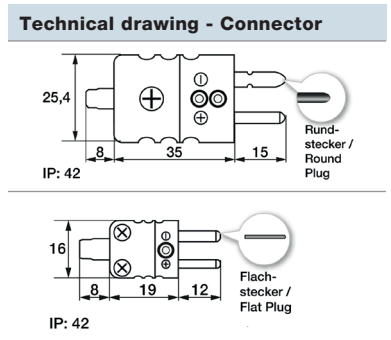
Other connectors available on request



H - Bend protection		
Picture	Length (mm)	Material
	50	Stainless steel spring 1.4310   SUS 302
	<b>Code</b>	<b>Feature</b>
	H0	Without (Standard)
	H1	Metal bend protection

Your order code					
Order nr.	Mounting length	Material connection cable	Length connection cable	Connector	Bend protection
803160 1111	C_____	E_____	F_____	G_____	H_____

Delivery and Assembly	
Delivery and Packaging	w Probe, separately packaged in PE bag
Assembly instructions	per process connection

**Important assembly advices**

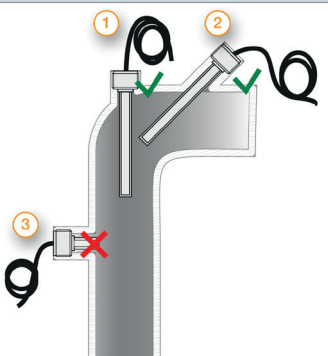

Measurement errors can occur due to heat dissipation to the environment. To keep these as small as possible, we recommend immersing the protection sleeve of your temperature probe as deeply as possible in the medium to be measured during installation. The optimum installation depth should be 10-15 times the Ø of the protection sleeve or, when using an immersion sleeve, the Ø of the immersion sleeve. When installing in pipelines whose Ø does not have a sufficiently deep installation depth, you should install the probe either at an angle or in a pipe elbow. Make sure that there is sufficient space for the probe to be removed. 1) Installation with sufficient installation depth 2) Installation at an angle with small pipe Ø 3) Not like this: Minimum installation depth not reached

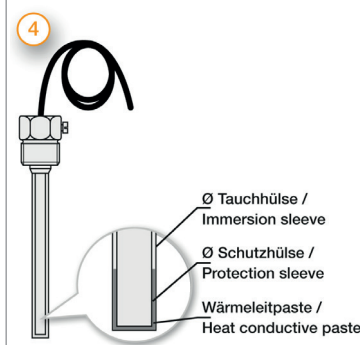

Installation by using an immersion sleeve (4): Please ensure that the Ø and length of the immersion sleeve are selected to suit the installation situation so that the minimum immersion depth can be achieved. Please also pay attention to the correct process connection. Since the probe is not inserted directly into the medium, but via the immersion sleeve, the response times are somewhat slower. The probe should be selected in such a way that the protection sleeve touches the bottom of the immersion sleeve and that the air cushion around the protection sleeve is as small as possible. The use of thermal paste can improve the response times. Please lay the cable in such a way that no water can penetrate the probe and with reserve loop (4). This allows you to extend the probe without disconnecting the electrical connection.



**Technical drawing (All dimensions in mm)**

**Customizable options**

C - Mounting length  
E - Material connection cable

F - Length connection cable  
G - Connector  
H - Bend protection

**Version with insulated end ferrules**

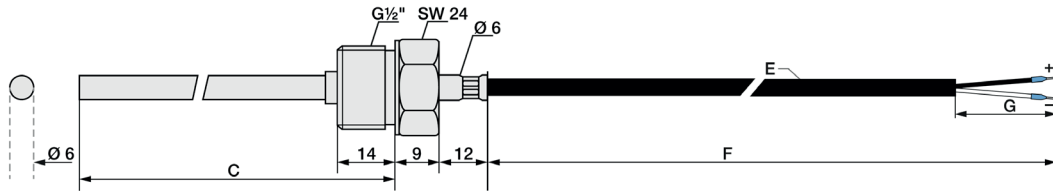

**Version with mini TE connector**

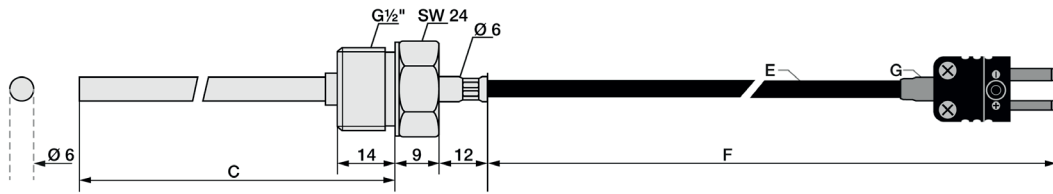

**Version with TE connector**

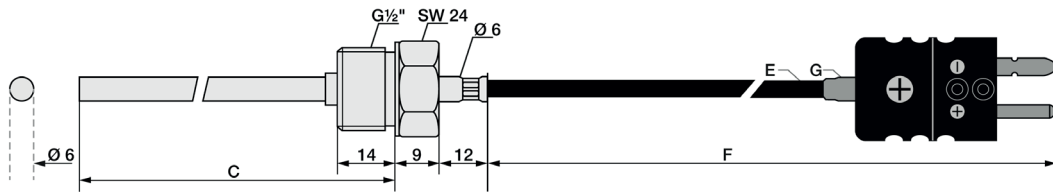

# Matching accessories: Thermocouple cables & Connector

Thermocouple cables - Please select your desired cable first.												
Order code	Type	Color	IP	From (°C) <sup>1)</sup>	To (°C) <sup>1)</sup>	Outside material	Material strand	Ø (mm) <sup>2)</sup>	Q (mm <sup>2</sup> )	Color strand	Ω / m <sup>4)</sup>	
809310 1	Thermocouple cable	Type J <sup>3)</sup>	IP67	-50	+180	Silicone	FEP	3,6	0,22	bk, wt	2,5	

Insulation resistance: ≥ 100 MOhm at min. 100 VDC | <sup>1)</sup>per. °C range | <sup>2)</sup>Tolerance ± 0.2 mm | <sup>3)</sup>Color according to IEC 584 | <sup>4)</sup>per thermocouple

Now please select the length and add the code to the article no. of the cable.

Length (m)	1	2	5	10	20
Code	010	020	050	100	200

Please append these digits to the part number of your desired cable.

## Matching accessories: Connector

Connector					
Picture	Code	Feature	Picture	Code	Feature
	809140 1000	Mini-TC connector Type J bk		809100 1000	Mini-TC coupling Type J bk
	809150 1000	TC connector Type J bk		809110 1000	TC coupling Type J bk

Other connectors available on request

### Technical drawing - Connector

The technical drawings show the following dimensions and features:

- Mini-TC coupling (Type J bk):** Dimensions: 25.4 mm height, 8 mm width, 35 mm length, 15 mm plug length. IP: 42. Label: Rundstecker / Round Plug.
- TC coupling (Type J bk):** Dimensions: 16 mm height, 8 mm width, 19 mm length, 12 mm plug length. IP: 42. Label: Flachstecker / Flat Plug.
- TC connector (Type J bk):** Dimensions: 25.4 mm height, 8 mm width, 25.4 mm length. IP: 42.

## Matching accessories: Heat-conducting paste

Heat-conducting paste		
Article no.	809540 1000	
Content	10 ml	
Thermal conductivity	>2.5 W/mK	
Min / Max °C	-30 °C to +280 °C	
Thermal resistance	< 0.126	

Details of accessories can be found on our website.

RL / KS / 28.10.2021



# Matching accessories: Immersion sleeves

Details of accessories can be found on our website.

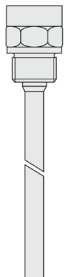
Immersion sleeves		Please select Ø and mounting length and append the codes to your order code.				
Picture	Immersion sleeve G1/2 " with internal thread	Code	Ø Inside / Outside (mm)	Code	Mounting length (mm)	
	Article no.	809520 3XXX				
	Temp. max	+600 °C				
	pressure proof until	40 bar	1	6,5 / 9	03	30
	Material	Stainless steel 1.4571   316TI	2	7,5 / 10	08	80
	Process connection	G1/2 "	3	8,5 / 11	13	130
	Wrench size	27	4	9,5 / 12	18	180
	Screw-in thread	G1/2 "			23	230
	Scope of delivery	Immersion sleeve, packed in PE bag			28	280
					38	380
	Your order code	809520 3	-		--	

### Technical drawing Immersion sleeves

