

Plug-in temperature transmitter B-head 0-10 V

Article number: 803310 1013

For our active immersion probe with B-head and voltage output 0-10 V, you will find suitable immersion sleeves and mounting flanges in the accessories for their quick and easy installation. The transmitter has eight switchable measuring ranges up to 150 °C and a connection head with either a cable gland, an M12 plug connector or a pressure screw.

Supply and output	
Output	0 - 10 V
Power consumption	< 1,0VA / 24V AC; < 0,55VA / 24V DC
Voltage supply	24 V AC/DC (± 10 %)
Connection type	3-Wire

General information	
Measuring range	multi-range switching with 8 switchable measuring ranges Tmax = +150°C with manual zero point correction (± 10 K)
Sensor	Pt1000, DIN EN 60751, Class B
Temperature deviation	typically ± 0.2 K at +25 °C
Load resistance	RI > 5 kOhm
Process connection	by using an immersion sleeve or mounting flange

Ambient conditions	
Ambient temperature	-30 °C to +70 °C
Permissible air humidity	< 95 % r. H., non-precipitating air

Certifications / Standards	
Protection class	III (nach EN 60 730)
Protection type	IP 54 according to EN 60 529 For adjusting screw IP 65 according to EN 60 529 For M12 connector and cable gland
Standards	CE conformity electromagnetic compatibility according to EN 61326 according to EMC Directive 2014/ 30/ EU

Protection sleeve		C - Mounting length			
Material	Stainless steel 1.4571 316Ti	Code	Length (mm)	Code	Length (mm)
Ø (mm)	6	C0050	50	C0250	250
		C0100	100	C0300	300
		C0150	150	C0350	350
		C0200	200	C0400	400

Other mounting lengths on request | tolerance ± 1 mm

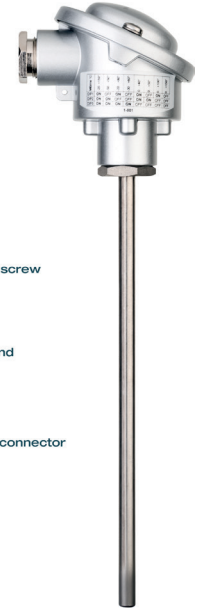

Configurable options
C - Mounting length
K- Screw connection

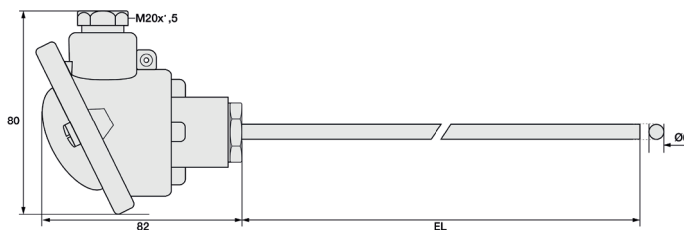
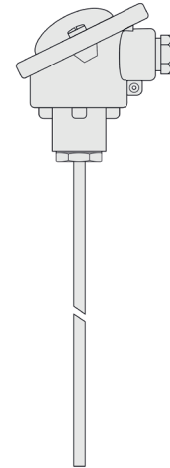

MW / KS / 22.05.2023

Testo Sensor GmbH

Testo-Straße 1
D-79853 Lenzkirch

+49 7653 96597-0
+49 7653 96597-99

info@testo-sensor.de
www.testo-sensor.de

You can find our standard portfolio in our
webshop at: www.testo-sensor.shop

Connection head	
Form	Form B
Material	Aluminium
Colour	RAL 9006 white aluminium
W/H/Ø (mm)	80/73/70
Electrical connection	Screw terminals max. 2.5 mm ²
Ambient temperature max	+70 °C
Measuring insert	fixed

K - Screw connection

Code	Screw connection	
K1	M12 plug connector, Acc. DIN EN 617076-2-101	
K2	Adjusting screw, Metal, M20x1,5	
K3	Cable gland, Brass nickel-plated, M20x1,5, Strain relief, replaceable, 6-12 mm Ø Inner	

Your order code		
Article number	Mounting length	Screw connection
803310 1013	C_____	K_

Delivery and Packing	
Delivery	Transmitter, Operating instructions
Packing	individually packed in PE bag

MW / KS / 22.05.2023

Testo Sensor GmbH

Testo-Straße 1
D-79853 Lenzkirch

+49 7653 96597-0
+49 7653 96597-99

info@testo-sensor.de
www.testo-sensor.de

You can find our standard portfolio in our
webshop at: www.testo-sensor.shop

Technical drawing

Configurable options

- C - Mounting length
- K - Screw connection

All dimensions in mm

K1 - M12 plug connector

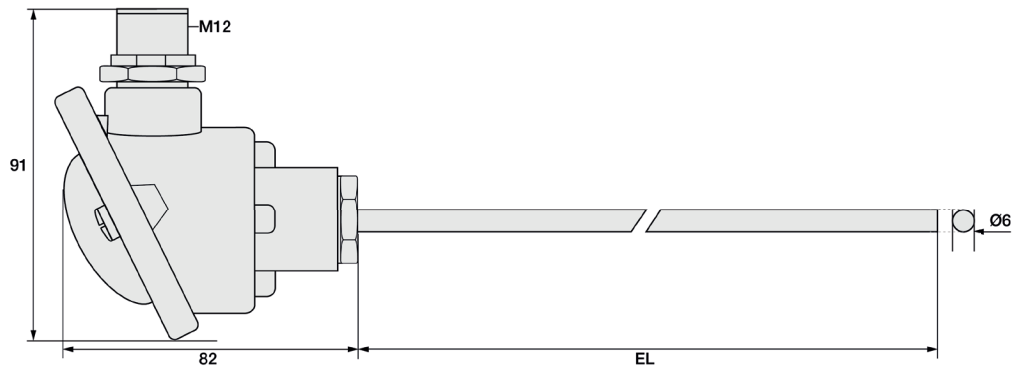

K2 - Adjusting screw

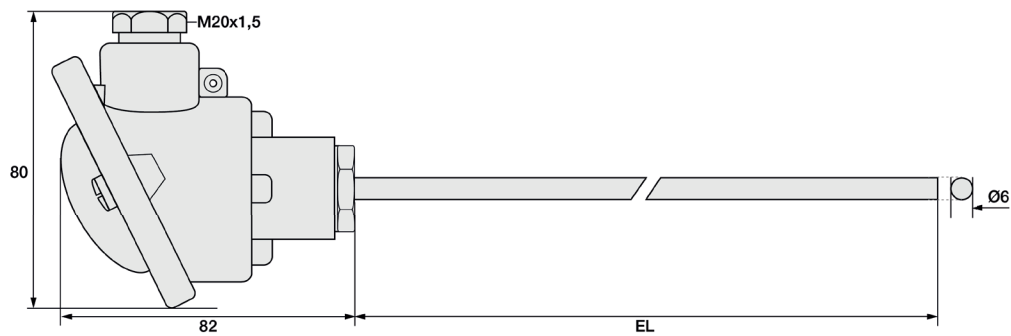

K3 - Cable gland

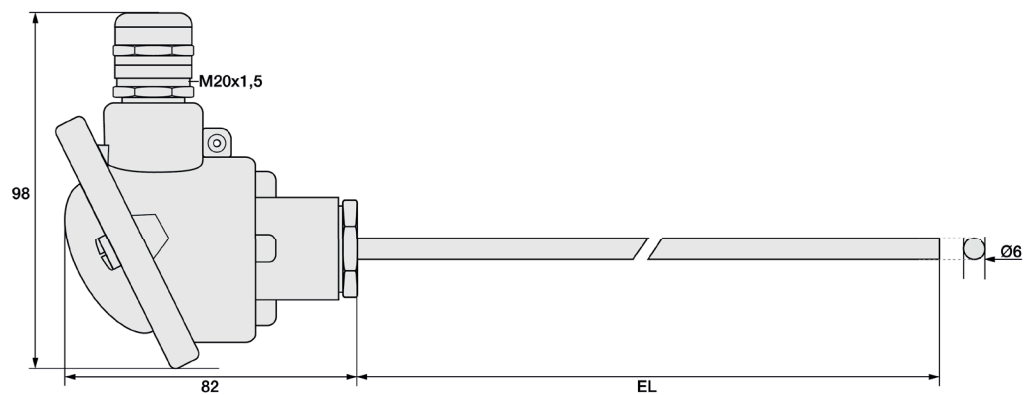

MW / KS / 22.05.2023

Testo Sensor GmbH

Testo-Straße 1
D-79853 Lenzkirch

+49 7653 96597-0
+49 7653 96597-99

info@testo-sensor.de
www.testo-sensor.de

You can find our standard portfolio in our
webshop at: www.testo-sensor.shop

Important assembly instructions

Measuring errors can occur due to heat dissipation to the environment. To keep these as small as possible, we recommend immersing the protection sleeve of your temperature probe as deeply as possible into the medium to be measured. The optimum installation depth should be 10-15 times the Ø of the protection sleeve or, when using an immersion sleeve, the Ø of the immersion sleeve. When installing in pipelines whose Ø does not have a sufficiently deep installation depth, you should either install the probe at an angle or in a pipe elbow. Make sure that there is sufficient space for the probe to be removed. 1) Installation with sufficient installation depth 2) Installation at an angle with small pipe Ø 3) Not like this: Minimum installation depth not reached

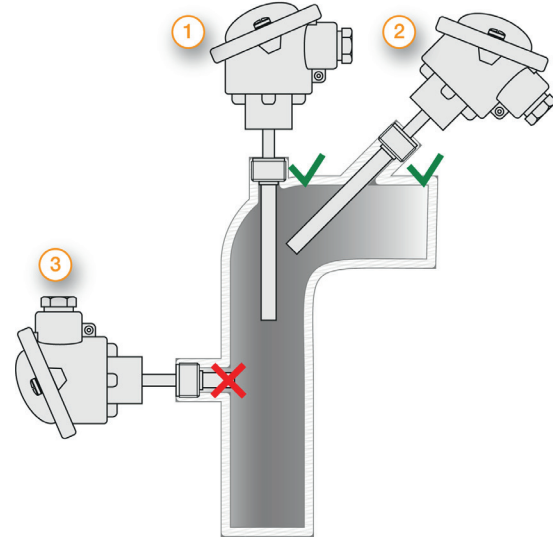

Installation by means of compression fitting: Please tighten the union nut of the compression fitting by hand as far as it will go (clearly noticeable). For compression fittings with PTFE pressure ring, use a wrench that matches the wrench size and make a 1/4 turn. These compression fittings can be used several times in this way. In the case of compression fittings with a stainless steel cutting ring, the compression fitting connects to the protective tube. This connection is pressure-resistant up to 40 bar. However, the compression fitting can only be used once. It must also be tightened more firmly. Please tighten it with 1 3/4 turns.

Mounting by means of a mounting flange: Please ensure that the Ø of the mounting flange matches the Ø of the protection sleeve. For B-head fittings with very long protection sleeves, we recommend a stainless steel or aluminium mounting flange due to its stability.

Mounting by using an immersion sleeve (4): Please ensure that the Ø and the length of the immersion sleeve are selected to suit the installation situation so that the minimum immersion depth can be achieved. Since the probe is not inserted directly into the medium, but via the immersion sleeve, the response times are somewhat slower. The probe should be selected so that the protection sleeve touches the bottom of the immersion sleeve and the air cushion around the protection tube is as small as possible. The use of thermal paste can improve the response times.

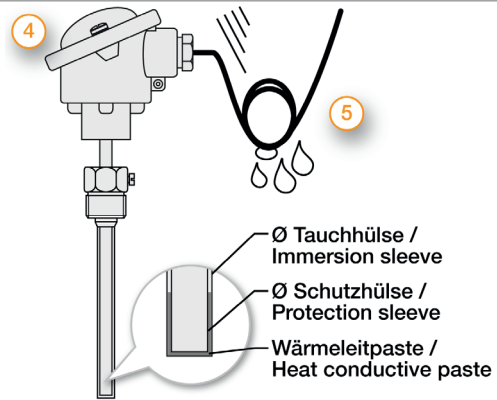

Please lay the cable with a reserve loop (5) and in such a way that no water can penetrate the sensor head. This will allow you to extend the probe without disconnecting the electrical connection.

Circuit diagrams and assignment (Please also read the operating instructions before connecting the transmitter)

<p>Wiring diagram</p>	<p>Pin assignment (M12)</p>	<p>1 = UB 24 V AC/DC 2 = Output temperature 0-10 V (°C) 3 = free 4 = -UB GND 5 = Shield</p>
-----------------------	-----------------------------	---

Measuring range (adjustable)	Dip 1	Dip 2	Dip 3	Measuring range (adjustable)	Dip 1	Dip 2	Dip 3
-20 °C to +150 °C	ON	ON	ON	0°C to +40 °C	ON	ON	OFF
-50 °C to +50 °C	OFF	ON	ON	0°C to +50 °C (Standard)	OFF	ON	OFF
-20 °C to +80 °C	ON	OFF	ON	0°C to +100 °C	ON	OFF	OFF
-30 °C to +60 °C	OFF	OFF	ON	0°C to +150 °C	OFF	OFF	OFF

MW / KS / 22.05.2023

Testo Sensor GmbH

Testo-Straße 1
 D-79853 Lenzkirch

+49 7653 96597-0
 +49 7653 96597-39

info@testo-sensor.de
 www.testo-sensor.de

You can find our standard portfolio in our
 webshop at: www.testo-sensor.shop

Matching accessoires: Immersion sleeves

Messing-Tauchhülse R1/2 " TH-MS				
Artikelnr.	809520 70XX	Code	EL (mm)	
Temp. max	+150 °C	05	50	
Druckdicht bis	10 bar	10	100	
Material	Messing vernickelt	15	150	
Prozessanschluss	R1/2 "	20	200	
Schlüsselweite	22	25	250	
Ø Innen / Außen (mm)	6,5 / 8	30	300	
Lieferumfang	Messing-Tauchhülse R1/2 " TH-MS	40	400	
Bestell Code	809520 70	--		

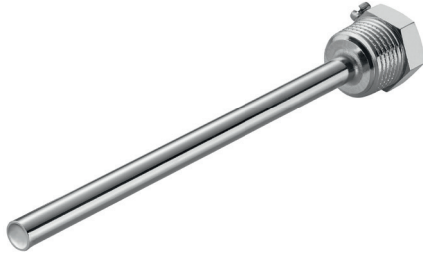

Bitte hängen Sie den Code für Ihre gewünschte Einbaulänge (EL) an die Artikelnr. an.

Technical drawing

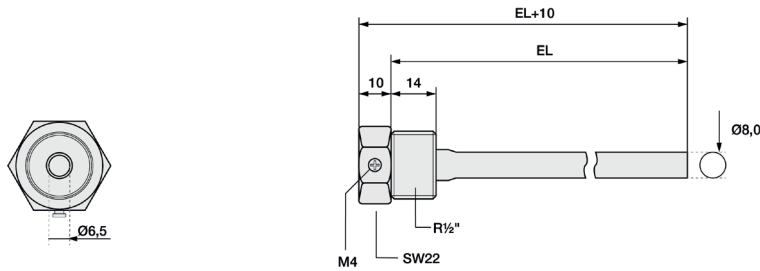

Edelstahl-Tauchhülse G1/2 " TH-VA				
Artikelnr.	809520 80XX	Code	EL (mm)	
Temp. max	+600 °C	05	50	
Druckdicht bis	40 bar	10	100	
Material	1.4571 (316TI)	15	150	
Prozessanschluss	G1/2 "	20	200	
Schlüsselweite	27	25	250	
Ø Innen / Außen (mm)	6,5 / 8	30	300	
Lieferumfang	Edelstahl-Tauchhülse G1/2 " TH-VA	40	400	
Ihr Bestell Code	809520 80	--		

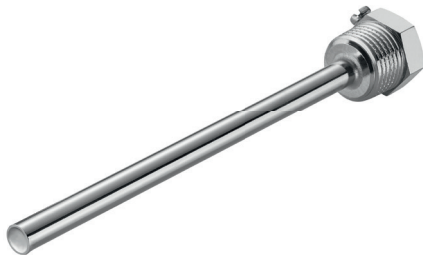

Bitte hängen Sie den Code für Ihre gewünschte Einbaulänge (EL) an die Artikelnr. an.

Technical drawing

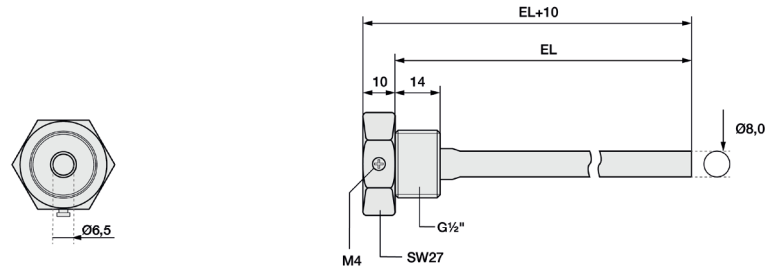

MW / KS / 22.05.2023

Testo Sensor GmbH

Testo-Straße 1
D-79853 Lenzkirch

+49 7653 96597-0
+49 7653 96597-99

info@testo-sensor.de
www.testo-sensor.de

You can find our standard portfolio in our
webshop at: www.testo-sensor.shop

Edelstahl-Tauchhülse G1/2 " mit Halsrohr TH-VA

Artikelnr.	809520 90XX	Code	EL (mm)
Temp. max	+600 °C	05	50
Druckdicht bis	40 bar	10	100
Material	1.4571 (316Ti)	15	150
Prozessanschluss	G1/2 "	20	200
Schlüsselweite	27	25	250
Ø Innen / Außen (mm)	6,5 / 8	30	300
Länge Halsrohr (mm)	90		
Lieferumfang	Edelstahl-Tauchhülse G1/2 " mit Halsrohr TH-VA		
Ihr Bestell Code	809520 80	--	

Bitte hängen Sie den Code für Ihre gewünschte Einbaulänge (EL) an die Artikelnr. an.

Technical drawing

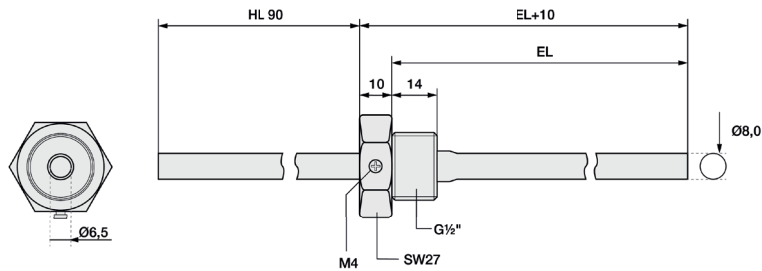

Stainless steel flange MF-06-M

Article number	809500 5060
Material	Edelstahl
Befestigung	3 x Ø 5 mm Bohrlöcher
Bohrung (mm)	6,3

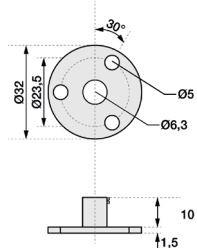

MW / KS / 22.05.2023

Testo Sensor GmbH

Testo-Straße 1
D-79853 Lenzkirch

+49 7653 96597-0
+49 7653 96597-99

info@testo-sensor.de
www.testo-sensor.de

You can find our standard portfolio in our
webshop at: www.testo-sensor.shop