

Screw-in probe G1/2 " with glass fibre cable

Order nr.: 803180 1011

Screw-in probes with glass fibre cables are shielded and measure the temperature in pipelines or vessels up to +400 °C. They are crimped and also have a poorer seal than other cables due to the insulation material used. To configure your screw-in probe for your measuring task, simply select the required configuration features and send us the order code.

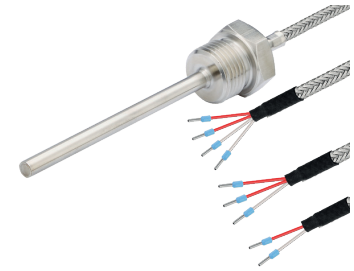

General Information	
Measuring range	-50 °C to +400 °C depending on sensor type and connection cable
Perm. °C range cable	-50 °C to +400 °C
Accuracy	depending on sensor type
Response time	t63 / t99: information is available on request
Pull-out force	≥ 30 N
Supply and output	
Max. measurement current	max. 1 mA
Supply voltage	approx. 5 V depending on measurement current
Measurement signal	passive (resistance value)
Ambient conditions	
Protection class	IP20 according DIN 60529 (depending on cable)
Humidity and moisture condensation resistance	according to application-specific qualification
Certificates and Standards	
Standards	DIN EN 61326-1:2013 DIN EN IEC 63000:2019-05
Directive	RoHS 2011/65/EU 2014/30/EU
Certificates	Certificate of suitability (on request)

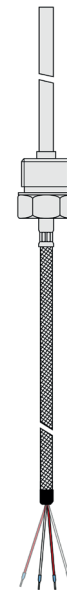

Customizable options

- A - Measuring element
- B - Connection type
- C - Mounting length
- E - Material connection cable
- F - Length connection cable
- G - Connector
- H - Bend protection

A - Measuring element				
Code	Sensor	Accuracy / Tolerance resistance	min ²⁾	max ²⁾
A012	Pt100	Cl. B dT = ±(0,30 °C + 0,005 t) ¹⁾	-50 °C	+400 °C
A011	Pt100	Cl. A dT = ±(0,15 °C + 0,002 t) ¹⁾	-50 °C	+300 °C
A013	Pt100	1/3 Cl. B dT = ±(1/3 · (0,30 °C + 0,005 t)) ¹⁾	-50 °C	+200 °C
A014	Pt100	1/10 Cl. B dT = ±(1/10 · (0,30 °C + 0,005 t)) ¹⁾	±0 °C	+100 °C
A022	Pt500	Cl. B dT = ±(0,30 °C + 0,005 t) ¹⁾	-70 °C	+500 °C
A032	Pt1000	Cl. B dT = ±(0,30 °C + 0,005 t) ¹⁾	-50 °C	+400 °C
A031	Pt1000	Cl. A dT = ±(0,15 °C + 0,002 t) ¹⁾	-50 °C	+300 °C
A105	NTC 5 kOhm	R25 = 5 KOhm ±1 %	-40 °C	+125 °C
A110	NTC 10 kOhm	R25 = 10 KOhm ±1 %	-40 °C	+125 °C
A120	NTC 20 kOhm	R25 = 20 KOhm ±1 %	-40 °C	+125 °C
A210	Ni1000	-60 °C to 0 °C: dT = ±(0,4 °C + 0,028 · T) 0 °C to +150 °C: dT = ±(0,4 °C + 0,007 · T)	-60 °C	+150 °C
A323	LM235Z	typical ±1 °C	-40 °C	+125 °C
A421	KTY 81-210	R25 = 2 KOhm ±1 %	-50 °C	+150 °C

¹⁾according to IEC 751 / EN 60751 | ²⁾ Perm. range °C | A105, A110, A120, A323, A421 only on request | The measuring range depends on the measuring element and the connecting cable. | Detailed information and the characteristics can be found in our download area.

B - Connection type	
Code	Conn. type
B2	2-Wire (2W)
B3	3-Wire (3W)
B4	4-Wire (4W)

Possible connections			
Sensor	2W	3W	4W
Pt	✓	✓	✓
NTC	✓		
Ni	✓	✓	✓
LM235Z	✓		
KTY	✓		



Screw-in thread					
Bild	Screw-in thread		C - Mounting length		Bild
	Material	Stainless steel 1.4301 SUS 304	Code	Length (mm)	
	Length (mm)	14	C0050	50 ¹⁾	
	Process connection	G1/2 "	C0100	100 ¹⁾	
	Wrench size	24	C0150	150 ¹⁾	
	Protection sleeve		C0200	200 ¹⁾	
	Material	Stainless steel 1.4571 316TI	C0250	250 ¹⁾	
	Mounting length (mm)	please choose	C0300	300 ¹⁾	
	Ø (mm)	6 ²⁾	C0400	400 ¹⁾	
		C0500	500 ¹⁾		

²⁾ Tolerance ± 0,1 mm | Other mounting lengths on request | ¹⁾Tolerance ± 1%

E - Cable material and configuration connection cable												
Picture	Code	Connection type	Color	IP	From (°C) ¹⁾	To (°C) ¹⁾	Outside material	Material strand	Color strand	Ø (mm) ²⁾	Q (mm ²) ³⁾	Ω / m ⁴⁾
	E3300	2-Wire	steel	IP20	-50	+400	Varnish	Glass fibre	rd, wt	3,2	0,22	0,09
	E3301	3-Wire	steel	IP20	-50	+400	Varnish	Glass fibre	rd, wt, rd	3,2	0,22	0,09
	E3302	4-Wire	steel	IP20	-50	+400	Varnish	Glass fibre	rd, wt, rd, wt	3,4	0,22	0,09

Insulation resistance: ≥ 100 MOhm at min. 100 VDC | ¹⁾Perm. range °C | ²⁾Tolerance ± 0,2 mm | ³⁾ Tolerance ± 0,03 mm² | ⁴⁾ per single strand

F - Length									
Code	F010	F020	F030	F040	F050	F100	F150	F200	
m	1	2	3	4	5	10	15	20	

Other lengths on request

G - Connector		
Picture	Code	Feature
	G01	Insulated end ferrules (50 mm)

H - Bend protection				
Picture	Length (mm)	Material	Code	Feature
	50	Stainless steel spring 1.4310 SUS 302	H0	Without (Standard)
			H1	Metal bend protection

Delivery and Assembly	
Assembly instructions	via process connection
Delivery and Packaging	Probe, seperatly packaged in PE bag

Your order code							
Order nr.	Measuring element	Connection type	Mounting length	Material connection cable	Length connection cable	Connector	Bend protection
803180 1011	A_____	B_____	C_____	E_____	F_____	G_____	H_____

RL / KS / 29.07.2021



Technical drawing

Customizable options

A - Measuring element
B - Connection type

C - Mounting length
E - Material connection cable

F - Length connection cable
G - Connector

H - Bend protection
All dimensions in mm

Ausführung 2-Leiter / 2-Wire version

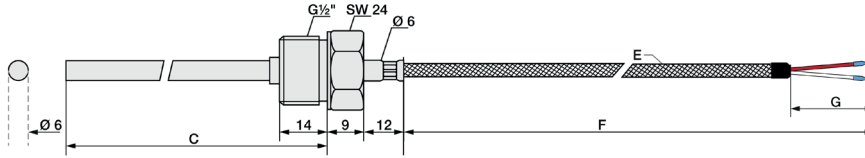

Ausführung 3-Leiter / 3-Wire version

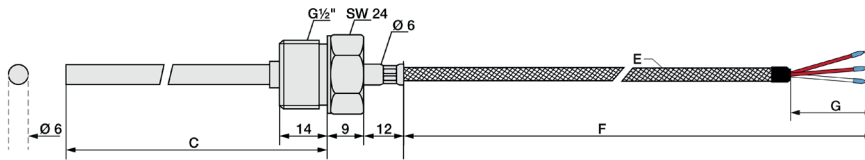

Ausführung 4-Leiter / 4-Wire version

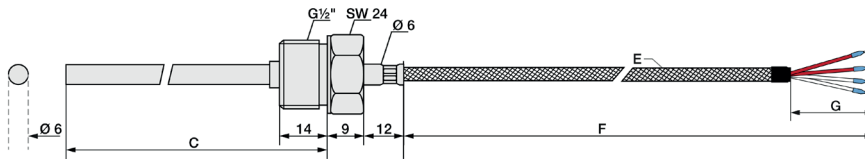

Delivery and Assembly

Delivery and Packaging Probe, separately packaged in PE bag

Important assembly advices

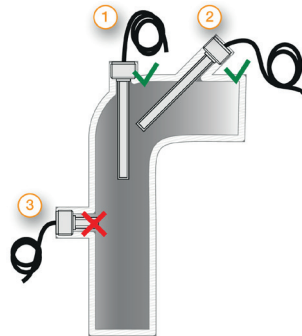

Measurement errors can occur due to heat dissipation to the environment. To keep these as small as possible, we recommend immersing the protection sleeve of your temperature probe as deeply as possible in the medium to be measured during installation. The optimum installation depth should be 10-15 times the Ø of the protection sleeve or, when using an immersion sleeve, the Ø of the immersion sleeve. When installing in pipelines whose Ø does not have a sufficiently deep installation depth, you should install the probe either at an angle or in a pipe elbow. Make sure that you have sufficient space so that the probe can be removed again. 1) Installation with sufficient installation depth 2) Installation at an angle with small pipe Ø 3) Not like this: Minimum installation depth not reached

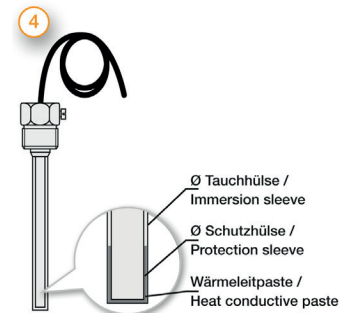

Installation by using an immersion sleeve (4): Please ensure that the Ø and length of the immersion sleeve are selected to suit the installation situation so that the minimum immersion depth can be achieved. Please also pay attention to the correct process connection. Since the probe is not inserted directly into the medium, but via the immersion sleeve, the response times are somewhat slower. The probe should be selected in such a way that the protection sleeve touches the bottom of the immersion sleeve and that the air cushion around the protection sleeve is as small as possible. The use of thermal paste can improve the response times.
Please lay the cable in such a way that no water can penetrate the probe and with reserve loop (4). This allows you to extend the probe without disconnecting the electrical connection.

RL / KS / 29.07.2021



Matching accessories

Details of accessories can be found on our website.

Heat-conducting paste				
Article no.	Content	Thermal conductivity	Min / Max °C	Thermal resistance
809540 1000	10 ml	>2.5 W/mK	-30 °C to +280 °C	< 0.126

Immersion sleeves		Please select Ø and mounting length and append the codes to your order code.				
Picture	Immersion sleeve G1/2 " with internal thread	Code	Ø Inside / Outside (mm)	Code	Mounting length (mm)	
	Article no.	809520 3XXX				
	Temp. max	+600 °C				
	pressure proof until	40 bar	1	6,5 / 9	03	30
	Material	Stainless steel 1.4571 316TI	2	7,5 / 10	08	80
	Process connection	G1/2 "	3	8,5 / 11	13	130
	Wrench size	27	4	9,5 / 12	18	180
	Screw-in thread	G1/2 "			23	230
	Scope of delivery	Immersion sleeve, packed in PE bag			28	280
					38	380
Your order code	809520 3	-		--		

