

# Screw-in temperature transmitter B-head 0-10 V

**Article number: 803311 2013**

The active screw-in probe with B-head and voltage output 0-10 V is supplied with a neck tube with G1/2 " screw-in thread for quick and easy installation. The transmitter has eight switchable measuring ranges up to 600 °C and a connection head with either a cable gland, an M12 plug connector or a pressure screw.

Supply and output	
Output	0 - 10 V
Power consumption	< 1,0VA / 24V AC; < 0,55VA / 24V DC
Voltage supply	24 V AC/DC (± 10 %)
Connection type	3-Wire
General information	
Measuring range	multi-range switching with 8 switchable measuring ranges with manual zero point correction (± 10 K)
Sensor	Pt1000, DIN EN 60751, Class B
Temperature deviation	typically ± 0.2 K at +25 °C
Load resistance	RI > 5 kOhm
Process connection	Screw-in thread G1/2 "
Ambient conditions	
Ambient temperature	-30 °C to +70 °C
Permissible air humidity	< 95 % r. H., non-precipitating air
Certifications / Standards	
Protection class	III (nach EN 60 730)
Protection type	IP 54 according to EN 60 529   For adjusting screw IP 65 according to EN 60 529   For M12 connector and cable gland
Standards	CE conformity electromagnetic compatibility according to EN 61326 according to EMC Directive 2014/ 30/ EU

Protection sleeve		C - Mounting length			
Material	Stainless steel 1.4571   316Ti	Code	Length (mm)	Code	Length (mm)
Ø (mm)	8	C0100	100	C0250	250
Length neck tube	90	C0150	150	C0300	300
Thread	G1/2 "	C0200	200	C0400	400
Wrench size	WS27				
Compressive strength	40 bar				

Other mounting lengths on request | tolerance ± 1 mm

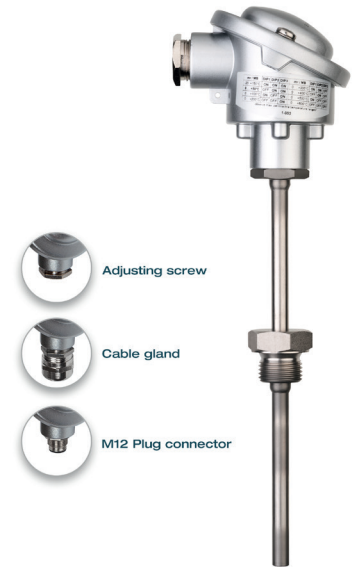

**Configurable options**  
C - Mounting length  
K- Screw connection

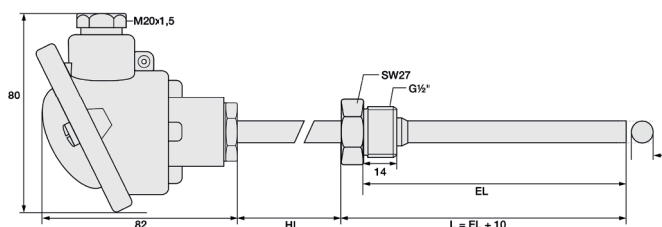
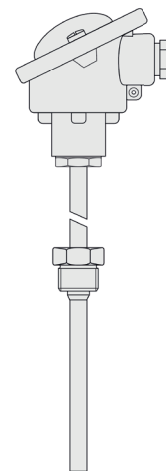

MW / KS / 22.05.2023

## Testo Sensor GmbH

Testo-Straße 1  
D-79853 Lenzkirch

+49 7653 96597-0  
+49 7653 96597-99

info@testo-sensor.de  
www.testo-sensor.de

You can find our standard portfolio in our  
webshop at: [www.testo-sensor.shop](http://www.testo-sensor.shop)

Connection head	
Form	Form B
Material	Aluminium
Colour	RAL 9006 white aluminium
W/H/Ø (mm)	80/73/70
Electrical connection	Screw terminals max. 2.5 mm <sup>2</sup>
Ambient temperature max	+70 °C
Measuring insert	fixed

**K - Screw connection**

Code	Screw connection	
K1	M12 plug connector, Acc. DIN EN 617076-2-101	
K2	Adjusting screw, Metal, M20x1,5	
K3	Cable gland, Brass nickel-plated, M20x1,5, Strain relief, replaceable, 6-12 mm Ø Inner	

Your order code		
Article number	Mounting length	Screw connection
803311 2013	C_____	K_

Delivery and Packing	
Delivery	Transmitter, Operating instructions
Packing	individually packed in PE bag

MW / KS / 22.05.2023

**Testo Sensor GmbH**

Testo-Straße 1  
D-79853 Lenzkirch

+49 7653 96597-0  
+49 7653 96597-99

info@testo-sensor.de  
www.testo-sensor.de

You can find our standard portfolio in our  
webshop at: [www.testo-sensor.shop](http://www.testo-sensor.shop)

**Technical drawing**

**Configurable options**

- C - Mounting length
- K - Screw connection

All dimensions in mm

**K1 - M12 plug connector**

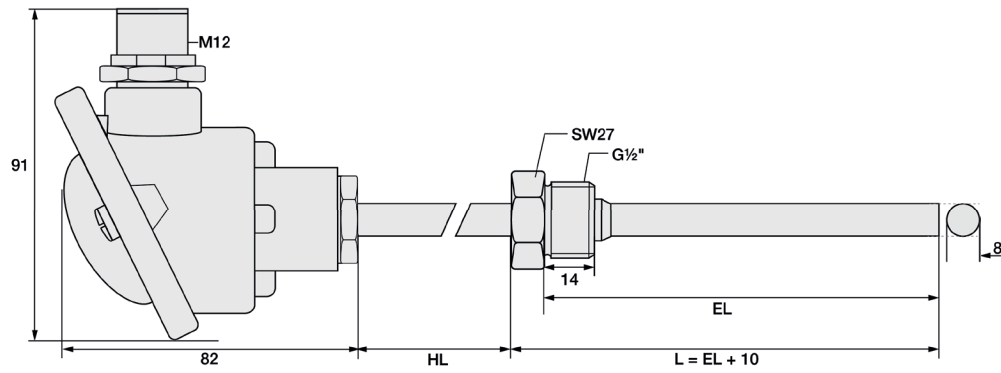

**K2 - Adjusting screw**

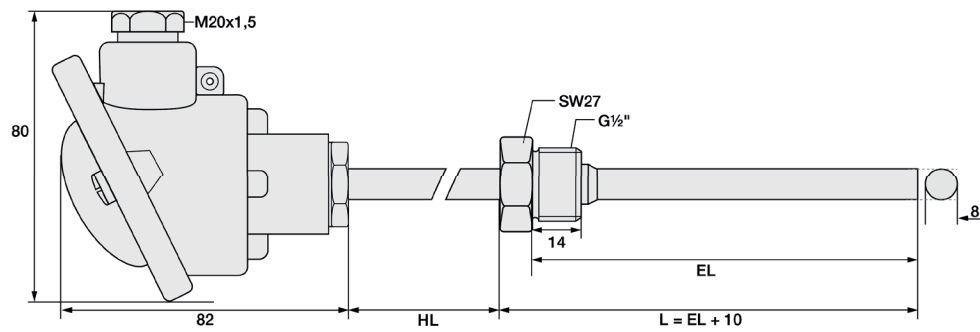

**K3 - Cable gland**

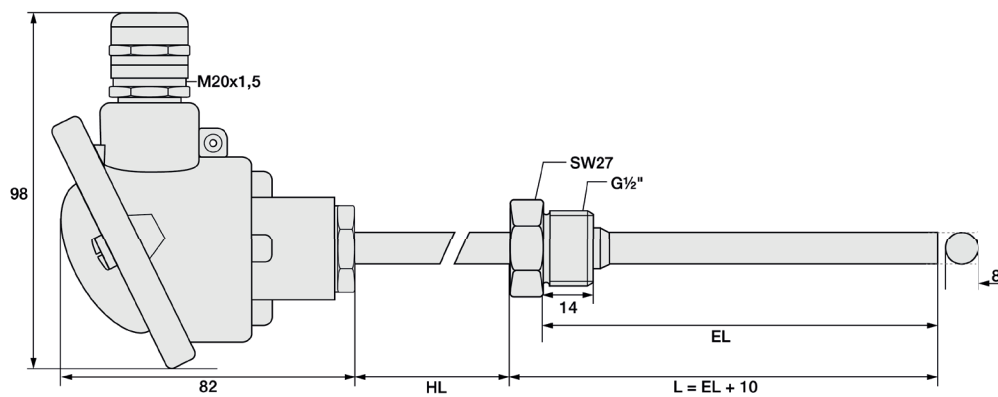

MW / KS / 22.05.2023

**Testo Sensor GmbH**

Testo-Straße 1  
D-79853 Lenzkirch

+49 7653 96597-0  
+49 7653 96597-99

info@testo-sensor.de  
www.testo-sensor.de

You can find our standard portfolio in our  
webshop at: [www.testo-sensor.shop](http://www.testo-sensor.shop)

**Important assembly instructions**

Measuring errors can occur due to heat dissipation to the environment. To keep these as small as possible, we recommend immersing the protection sleeve of your temperature probe as deeply as possible into the medium to be measured. The optimum installation depth should be 10-15 times the  $\varnothing$  of the protection sleeve or, when using an immersion sleeve, the  $\varnothing$  of the immersion sleeve. When installing in pipelines whose  $\varnothing$  does not have a sufficiently deep installation depth, you should either install the probe at an angle or in a pipe elbow. Make sure that there is sufficient space for the probe to be removed. 1) Installation with sufficient installation depth 2) Installation at an angle with small pipe  $\varnothing$  3) Not like this: Minimum installation depth not reached

Installation by means of compression fitting: Please tighten the union nut of the compression fitting by hand as far as it will go (clearly noticeable). For compression fittings with PTFE pressure ring, use a wrench that matches the wrench size and make a 1/4 turn. These compression fittings can be used several times in this way. In the case of compression fittings with a stainless steel cutting ring, the compression fitting connects to the protective tube. This connection is pressure-resistant up to 40 bar. However, the compression fitting can only be used once. It must also be tightened more firmly. Please tighten it with 1 3/4 turns.

Mounting by means of a mounting flange: Please ensure that the  $\varnothing$  of the mounting flange matches the  $\varnothing$  of the protection sleeve. For B-head fittings with very long protection sleeves, we recommend a stainless steel or aluminium mounting flange due to its stability.

Mounting by using an immersion sleeve (4): Please ensure that the  $\varnothing$  and the length of the immersion sleeve are selected to suit the installation situation so that the minimum immersion depth can be achieved. Since the probe is not inserted directly into the medium, but via the immersion sleeve, the response times are somewhat slower. The probe should be selected so that the protection sleeve touches the bottom of the immersion sleeve and the air cushion around the protection tube is as small as possible. The use of thermal paste can improve the response times.

Please lay the cable with a reserve loop (5) and in such a way that no water can penetrate the sensor head. This will allow you to extend the probe without disconnecting the electrical connection.

$\varnothing$  Tauchhülse / Immersion sleeve  
 $\varnothing$  Schutzhülse / Protection sleeve  
 Wärmeleitpaste / Heat conductive paste

**Circuit diagrams and assignment (Please also read the operating instructions before connecting the transmitter)**

Wiring diagram

Pin assignment (M12)

1 = UB 24 V AC/DC  
 2 = Output temperature 0-10 V (°C)  
 3 = free  
 4 = -UB GND  
 5 = Shield

Measuring range (adjustable)	Dip 1	Dip 2	Dip 3	Measuring range (adjustable)	Dip 1	Dip 2	Dip 3
					ON	ON	OFF
-20 °C to +150 °C	ON	ON	ON	0°C to +300 °C	ON	ON	OFF
0°C to +50 °C (Standard)	OFF	ON	ON	0°C to +400 °C	OFF	ON	OFF
0°C to +100 °C	ON	OFF	ON	0°C to +500 °C	ON	OFF	OFF
0°C to +200 °C	OFF	OFF	ON	0°C to +600 °C	OFF	OFF	OFF

MW / KS / 22.05.2023

**Testo Sensor GmbH**

Testo-Straße 1  
 D-79853 Lenzkirch

+49 7653 96597-0  
 +49 7653 96597-39

info@testo-sensor.de  
 www.testo-sensor.de

You can find our standard portfolio in our  
 webshop at: [www.testo-sensor.shop](http://www.testo-sensor.shop)